



FITMENT INSTRUCTIONS

FORD RANGER 2022 (DC & XC) CANOPY FITMENT INSTRUCTION

RANGER 22 DISCLAIMER

Ford has instructed us that the new Ford Ranger requires a reinforcement bracket for any canopy and accessory fitted to the vehicle's load body.

For information about the J Brace kit, contact your local Ford Dealer.

Ford part number: AMN1WJ27726AA

FITMENT OF J BRACE: The J Brace must be fitted prior to installing the canopy or canopy camper. Alu-Cab will not accept any liability for damages to the canopy or vehicle if the J Brace is not fitted or fitted post-fact.

All dealers, please note it will be your responsibility to record proof of fitment of the J Brace for warranty purposes.

Please note, our mounting brackets and hardware for canopies, are designed to be mounted directly to the load body, and not through a plastic loadbin liner.

Failure to remove or provide adequate clearance by way of cutting/modifying the liner to allow direct mounting to the load body, will result in an inferior installation that will void all warranties.

Please be sure to lay out all parts provided on a table or flat surface in order to check that all required parts are accounted for and prevent potential frustration at a later stage.

Preliminary Information

Installation and fitment instructions including tools required, fasteners included in kit, and the hardware included in kit. Please follow the instructions and check installation actions with the images in this document.



Please be sure to lay out all parts provided on a table or flat surface in order to check that all required parts are accounted for and prevent potential frustration at a later stage.

Installation Instructions

1

Canopy Fitment – Tools, Fasteners & Materials The tables below show the equipment, i.e. tools and fasteners required to start the canopy fitment of a Ford Ranger 2022 Double Cab.

1.1

Tools & Items Required

TOOL	
Ratchet	Flat Nose Pliers
Hand Drill	Phillips Screwdriver
10mm Socket	Panel Clip Removal Tool
13mm Socket	Flat Nose Pliers
13mm Ring Flat Spanner	
T40 Torx Bit	

1.2

Fasteners Supplied (included with canopy)

ITEM	QTY	ITEM	QTY
M8x20mm Hex Bolt	8	M8 Oversized Washer	20
M8x25mm Hex Bolt	6	M8 Spring Washer	16
M8x30mm Hex Bolt	8	M8 Nyloc Nuts	12
M8 35mm Hex Bolt	6	M8 Plastic Nut Caps	32
M8 Flat Washer	12		

Please be sure to lay out all parts provided on a table or flat surface in order to check that all required parts are accounted for and prevent potential frustration at a later stage.

Installation Instructions

1

Canopy Fitment – Tools, Fasteners & Materials The tables below show the equipment, i.e. tools and fasteners required to start the canopy fitment for a Ford Ranger 2022.

1.3

Hardware Required

ITEM	QTY
Front Left Mounting Bracket	1
Front Right Mounting Bracket	1
Rear Left Mounting Bracket	1
Rear Right Mounting Bracket	1
Universal Bracket	2
Ranger Rear Mounting Bracket	2
Standard Shim 01	32

1.4

Consumables Required

ITEM
Turpentine
Shop Rags
Black sealant, silicone or Sikaflex
Window Cleaner

Please be sure to lay out all parts provided on a table or flat surface in order to check that all required parts are accounted for and prevent potential frustration at a later stage.

Installation Instructions

2

Left, Right and Front Load Bin Capping.

Figure 1 and Figure 2 below are illustrations of the left and right replacement load bin capping for the Ford Ranger Double Cab 2022.

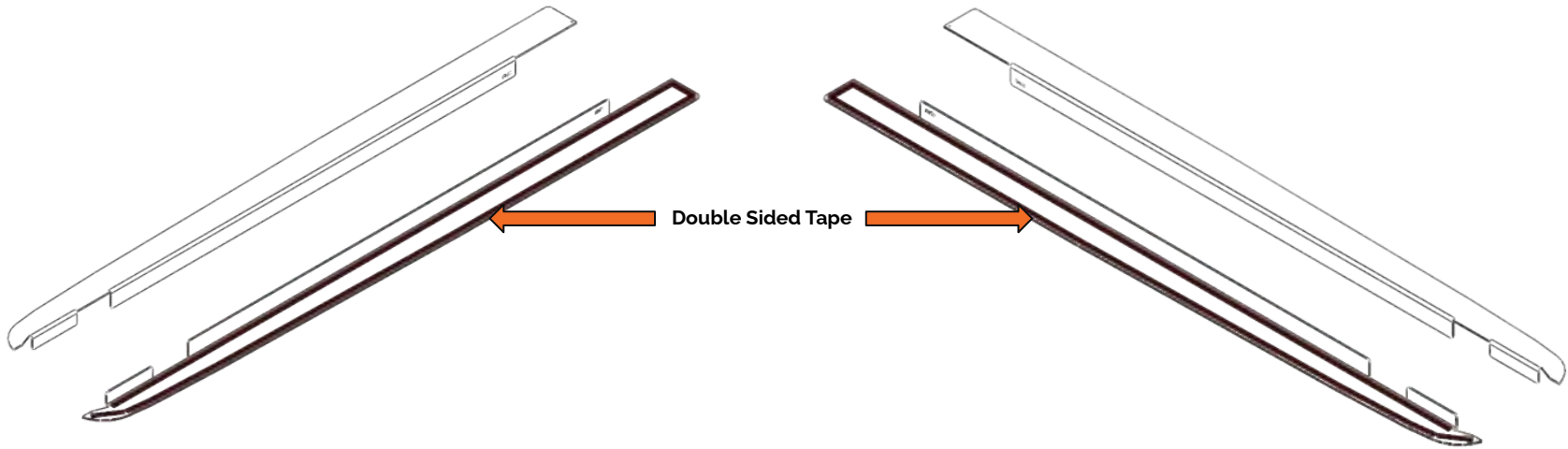

Fig 1. Left Load Bin Capping

Fig 2. Right Load Bin Capping

Installation Instructions

2

Front Load Bin Capping

Figure 3 below is an illustration of the front replacement load bin capping for the Ford Ranger Double Cab 2022.

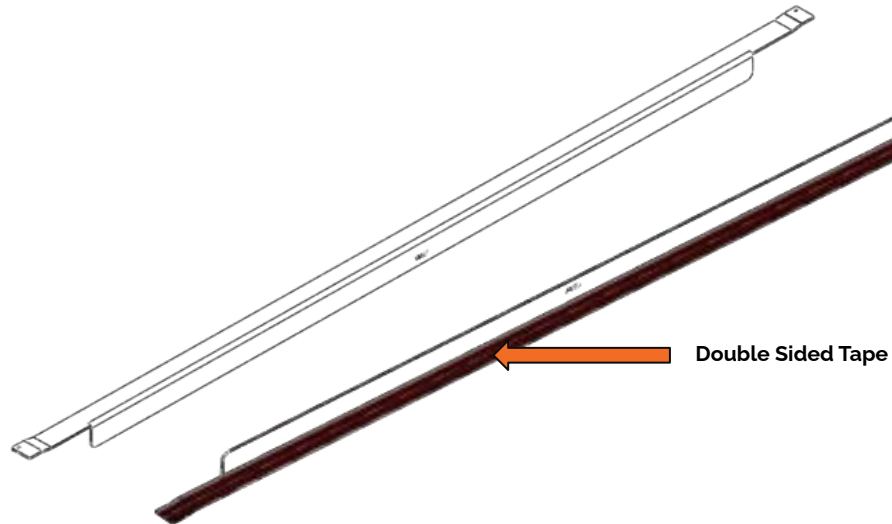

Fig 3. Front Load Bin Capping

Installation Instructions

2.1

Removing the OEM styling Bar

Figure 4 (Images A-F) below illustrates how to remove the OEM styling bar from the Ford Ranger 2022 double cab load bin sequentially.

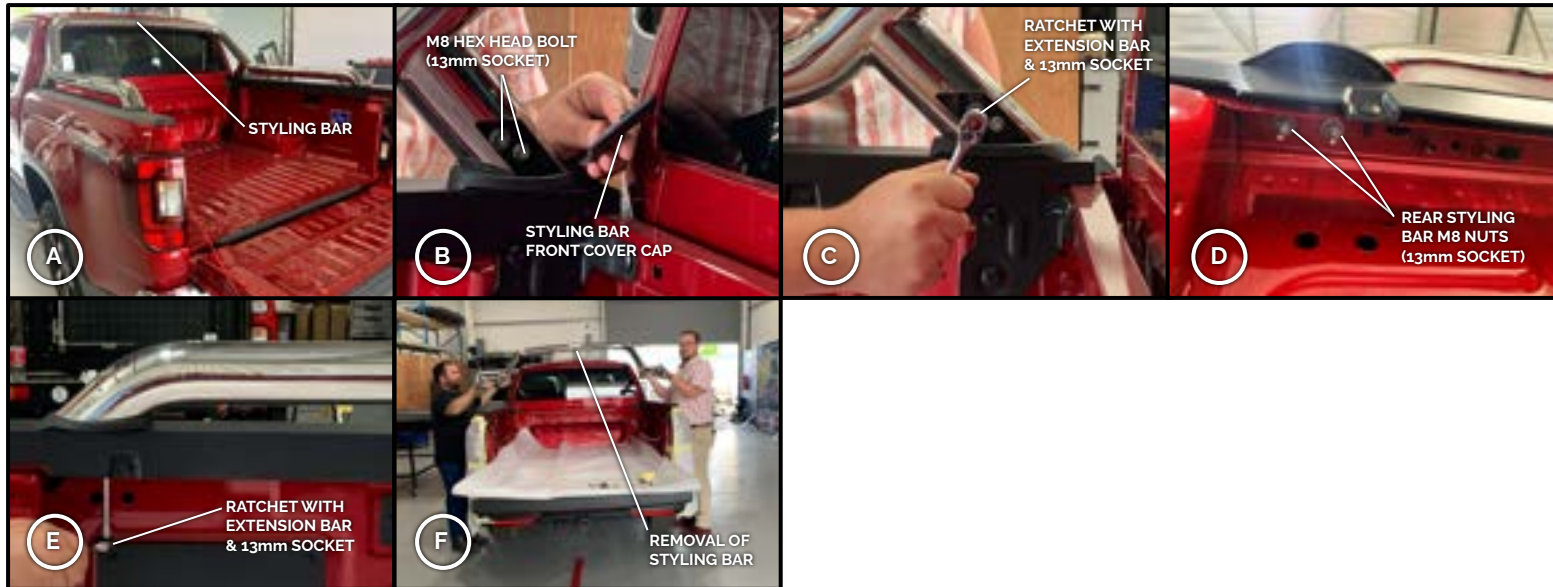

Fig 4. Image A - F

Installation Instructions

2.2

Removing the plastic capping

Figure 5 (Images G-L) below illustrate how to remove the left and right hand side plastic OEM loadbin capping.

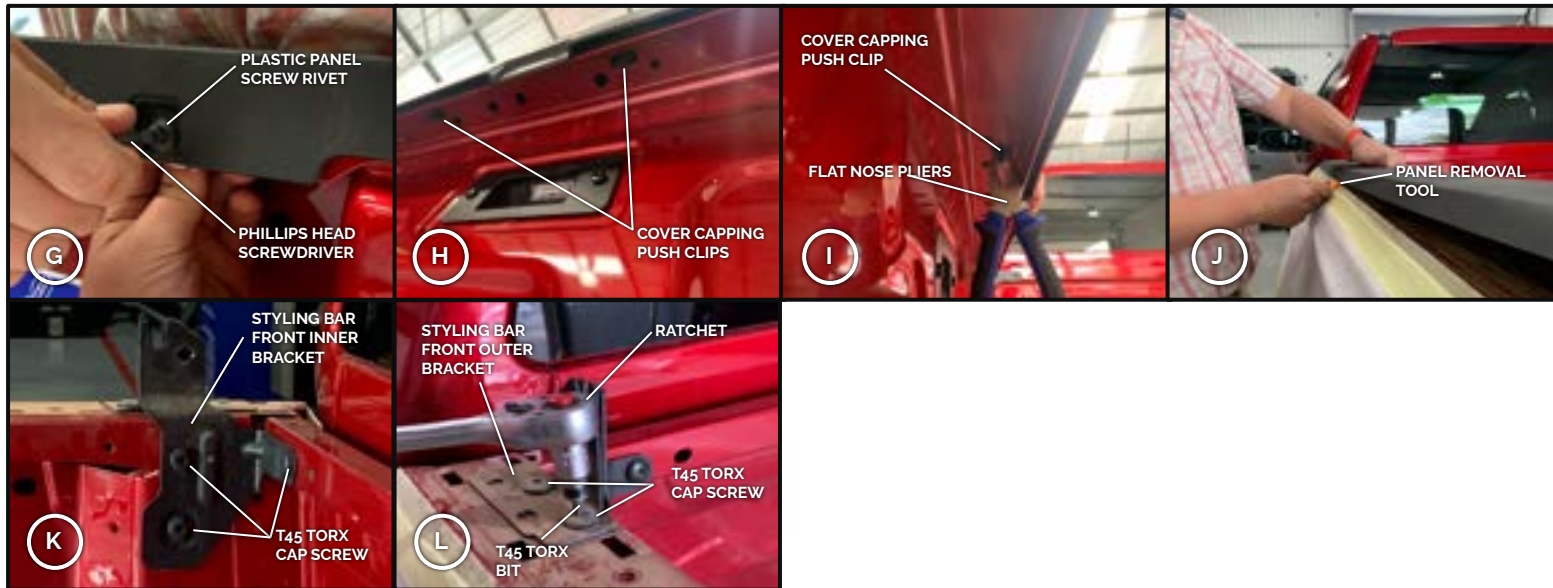

Fig 5. Image G - L

Installation Instructions

2.2

Removing the plastic capping (commercial double cab variant)

Figure 6 (Images M-T) below illustrate how to remove the left and right hand side plastic OEM loadbin capping as well as the tie down rails.

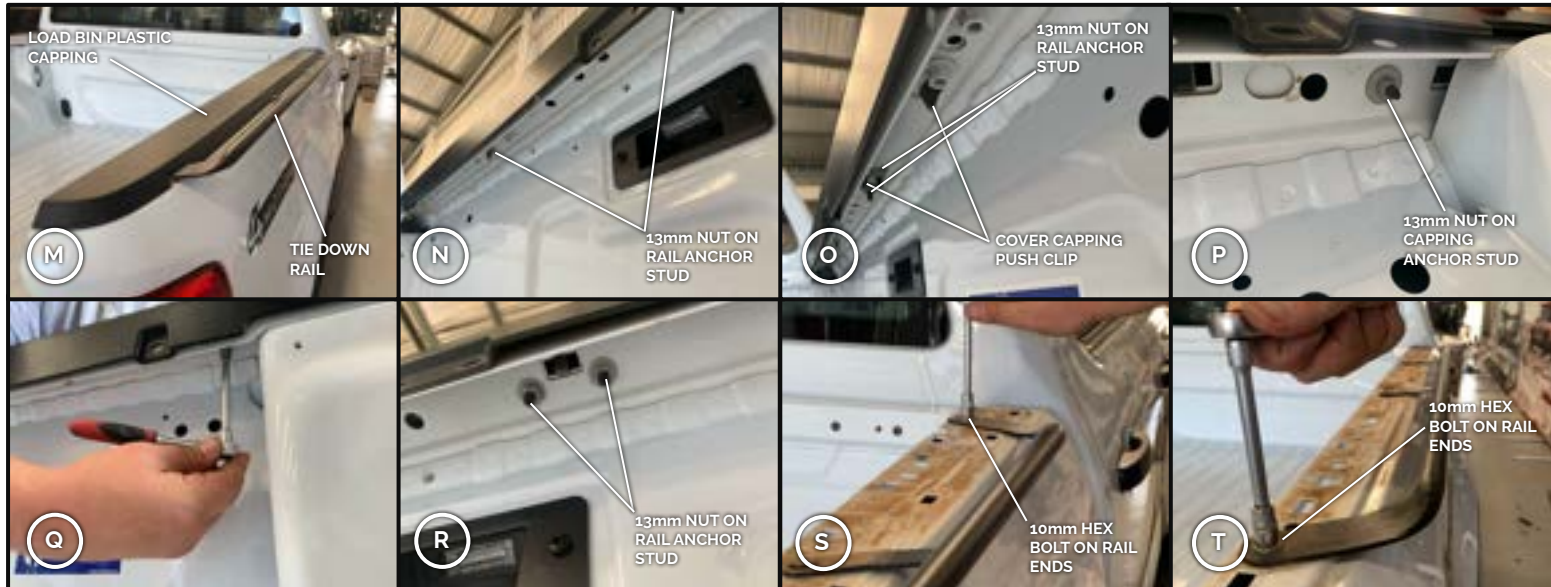

Fig 6. Image M - T

Installation Instructions

2.3

Installing the Canopy Load Bin Replacement Capping

Figure 7 (Images U-W) below illustrates how to install the load bin capping left, right and front replacement capping.

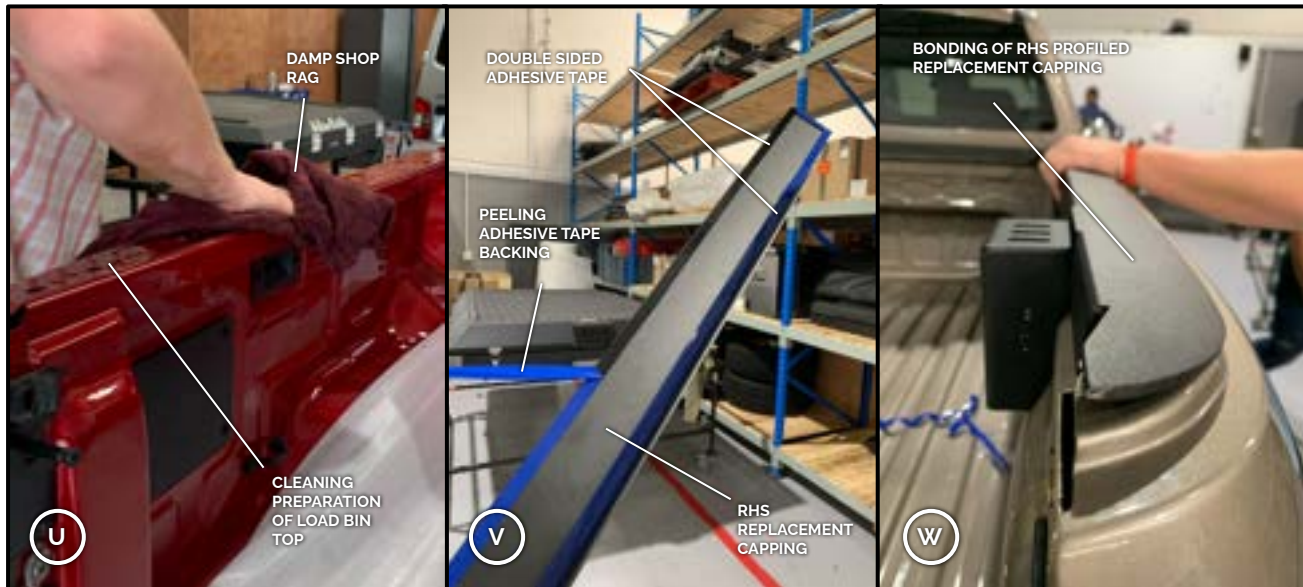

Fig 7. Image U - W

Installation Instructions

3

Removal of the Tie-down Loops

Figure 8 (Images X-Z) below illustrates illustrates the the position of the front and rear tie-down anchors which will need to be removed with a T45 Torx Bit.

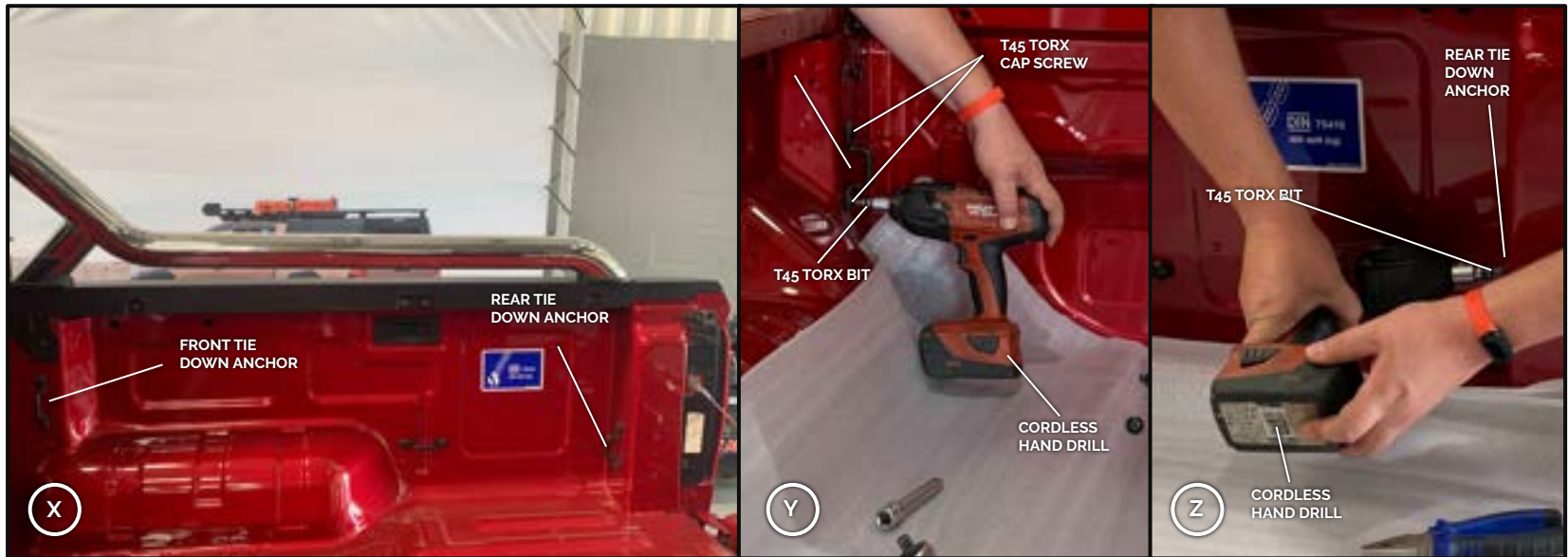

Fig 8. Image X - Z

Installation Instructions

3.1

Front and Rear Canopy Mounting Brackets

Figures 9 and 10 below illustrate the canopy mounting brackets for the Ford Ranger 2022 Double Cab.

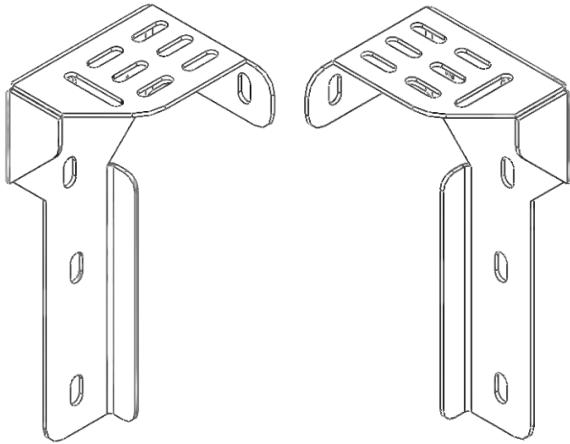

Fig 9. Front Left and Right Mounting Brackets

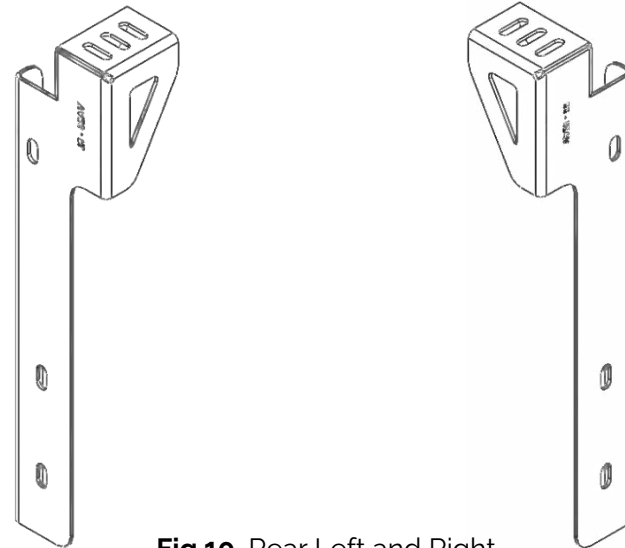

Fig 10. Rear Left and Right Mounting Brackets

Installation Instructions

3.2

Installing Front and Rear Mounting Brackets.

Figure 11 and 12 below illustrates the front right and left mounting bracket position on the load bin respectively.

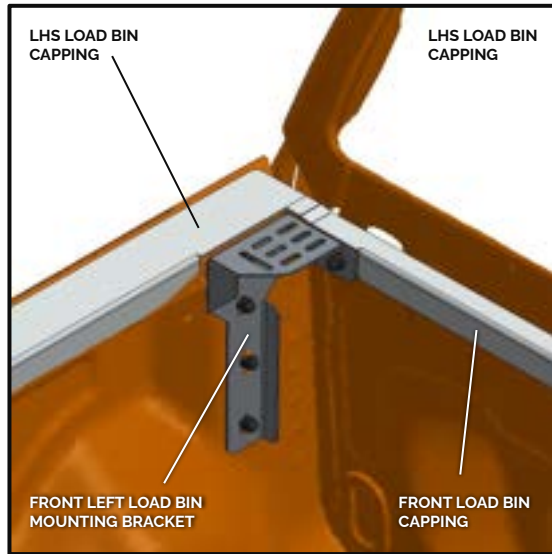

Fig 11. Right Front Mounting Bracket

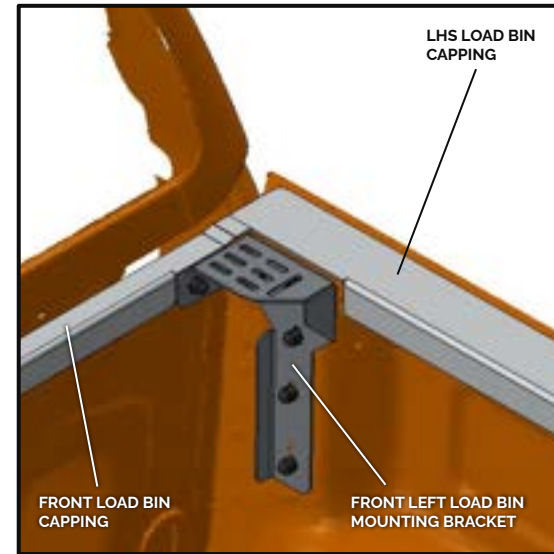

Fig 12. Left Front Mounting Bracket

Installation Instructions

3.3

Installing Front and Rear Mounting Brackets.

Figure 13 and 14 below illustrates the front right and left mounting bracket position on the load bin respectively.



Fig 13. Left Rear Mounting Bracket



Fig 14. Left Front Mounting Bracket

Installation Instructions

3.4

Figure 15 Cross-section of the load bin illustrating front, rear and centre mounting brackets in their respective positions.

Fig 15. Load Bin Cross-section

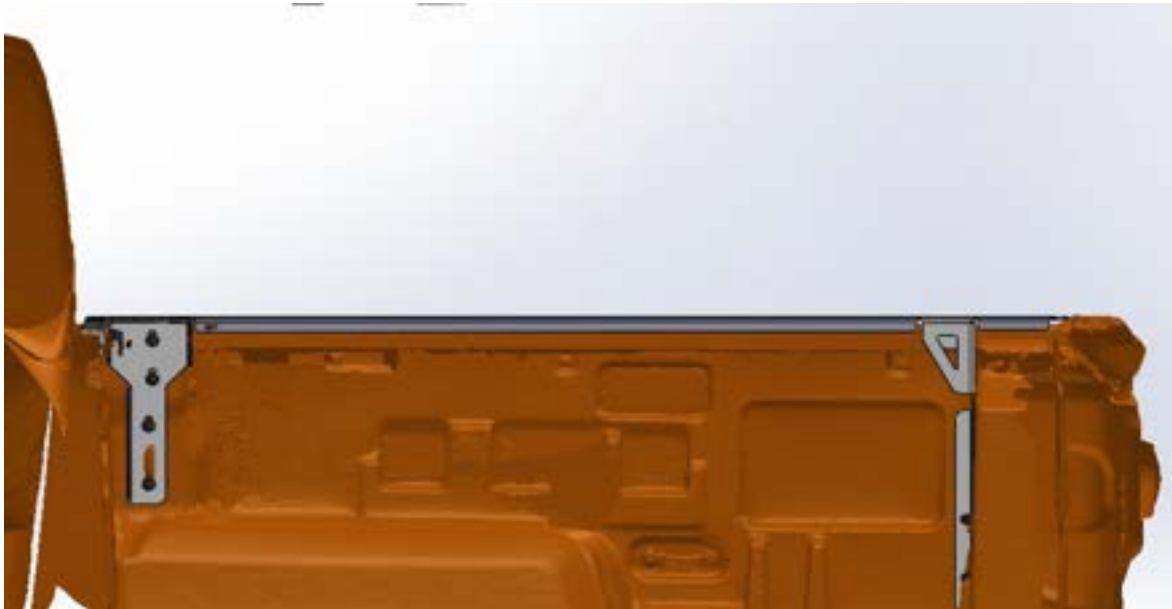

Installation Instructions

3.5

Figure 16 below illustrates the Front Right Mounting Bracket Sub-Assembly

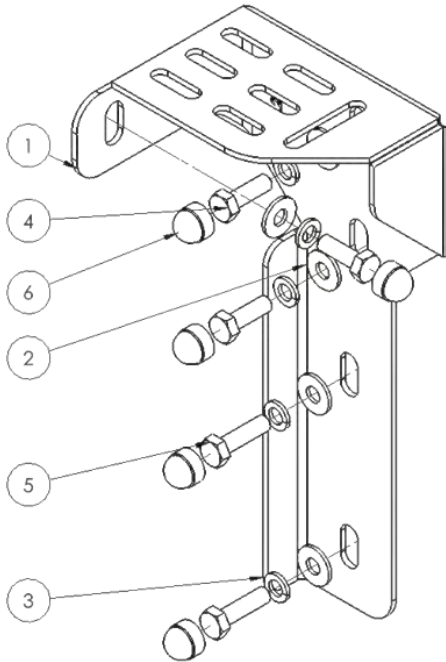

ITEM NO.	PART NUMBER	DESCRIPTION	QTY
1	C2-VA23-M-BKT-P001	FORD RANGER CANOPY FRONT RIGHT MOUNTING BRACKET	1
2	FFW-M8	M8x20mm OVERSIZED WASHER S/S - DIN 9021	5
3	SW-M8	M8 SPRING WASHER S/S	5
4	HEX-M8x25	M8x25 HEX BOLT S/S	3
5	HEX-M8x30	M8x30 HEX BOLT S/S	2
6	NCAP-M8	NUT CAP-o8mm	5

Fig 16. Front Right Mounting Bracket Assembly

Installation Instructions

3.6 Figure 17 below illustrates the Front Left Mounting Bracket Sub-Assembly

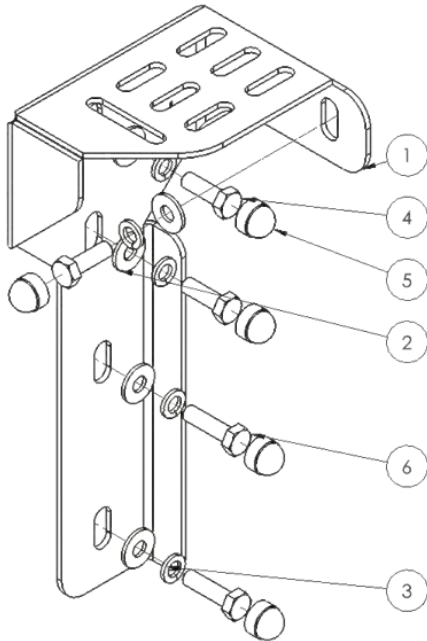

ITEM NO.	PART NUMBER	DESCRIPTION	QTY
1	C2-VA23-M-BKT-P002	FORD RANGER CANOPY FRONT LEFT MOUNTING BRACKET	1
2	FFW-M8	M8x20mm OVERSIZED WASHER S/S - DIN 9021	5
3	SW-M8	M8 SPRING WASHER S/S	5
4	HEX-M8x25	M8x25 HEX BOLT S/S	3
5	NCAP-M8	NUT CAP-08mm	5
6	HEX-M8x30	M8x30 HEX BOLT S/S	2

Fig 17. Front Left Mounting Bracket Assembly

Installation Instructions

3.7

Figure 18 below illustrates the Rear Right Mounting Bracket Sub-Assembly

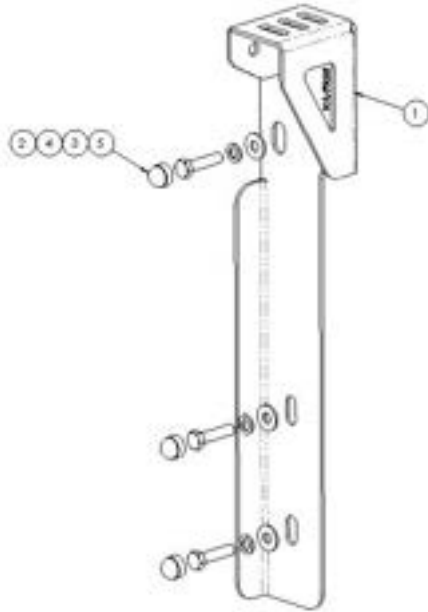

ITEM NO.	PART NUMBER	DESCRIPTION	QTY
1	C2-VA23-M-BKT-P003	FORD RANGER CANOPY REAR RIGHT MOUNTING BRACKET	1
2	FFW-M8	M8x20mm OVERSIZED WASHER S/S - DIN 9021	3
3	SW-M8	M8 SPRING WASHER S/S	3
4	HEX-M8x35	M8x35 HEX BOLT S/S	3
5	NCAP-M8	NUT CAP-o8mm	3

Fig 18. Rear Right Mounting Bracket Assembly

Installation Instructions

3.8

Figure 19 below illustrates the Rear Left Mounting Bracket Sub-Assembly

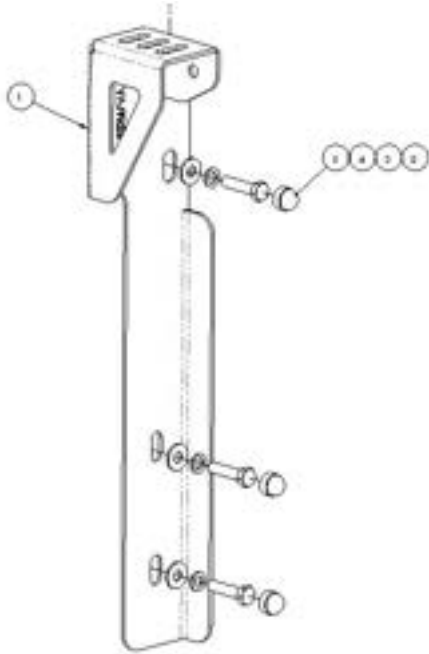

ITEM NO.	PART NUMBER	DESCRIPTION	QTY
1	C2-VA23-M-BKT-P004	FORD RANGER CANOPY REAR LEFT MOUNTING BRACKET	1
2	FFW-M8	M8x20mm OVERSIZED WASHER S/S - DIN 9021	3
3	SW-M8	M8 SPRING WASHER S/S	3
4	HEX-M8x35	M8x35 HEX BOLT S/S	3
5	NCAP-M8	NUT CAP-o8mm	3

Fig 19. Rear Left Mounting Bracket Assembly

Installation Instructions

4.1

Canopy Installation

Figure 20 below illustrates the alignment of the canopy from front to back and Figure 21 illustrates the position of the canopy-to-load-bin mounting bracket positions.

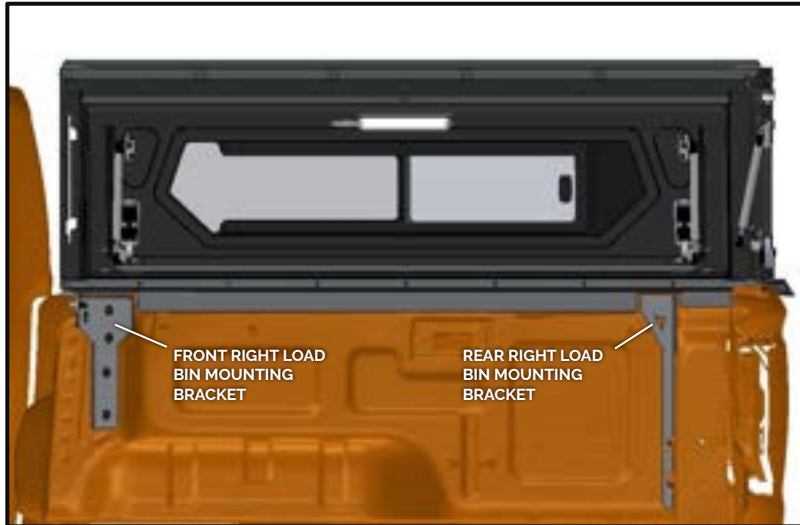

Fig 20. Section of Canopy on Load Bin



Fig 21. Position of Canopy Mounting Brackets

Installation Instructions

4.2

Canopy Installation

Figures 22 and 23 below illustrate how the canopy mounting brackets key into the nut-slots in the base frame of the canopy and how to use the shim plates for completing the mounting of the Ford Ranger Double Cab 2022 Canopy.

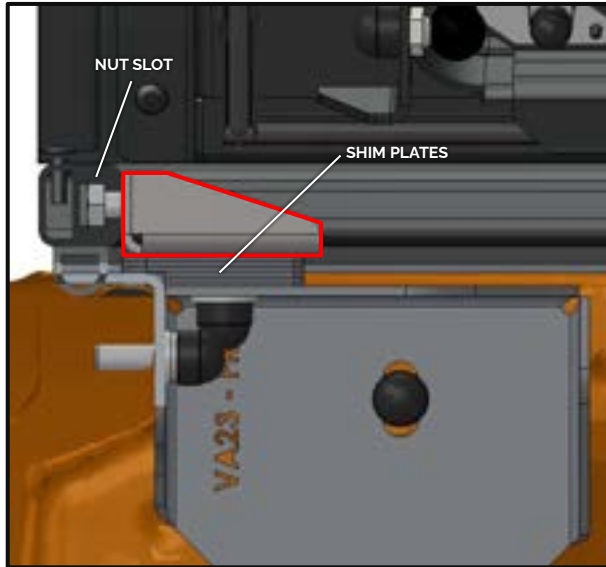

Fig 22. Universal Canopy Mounting Bracket

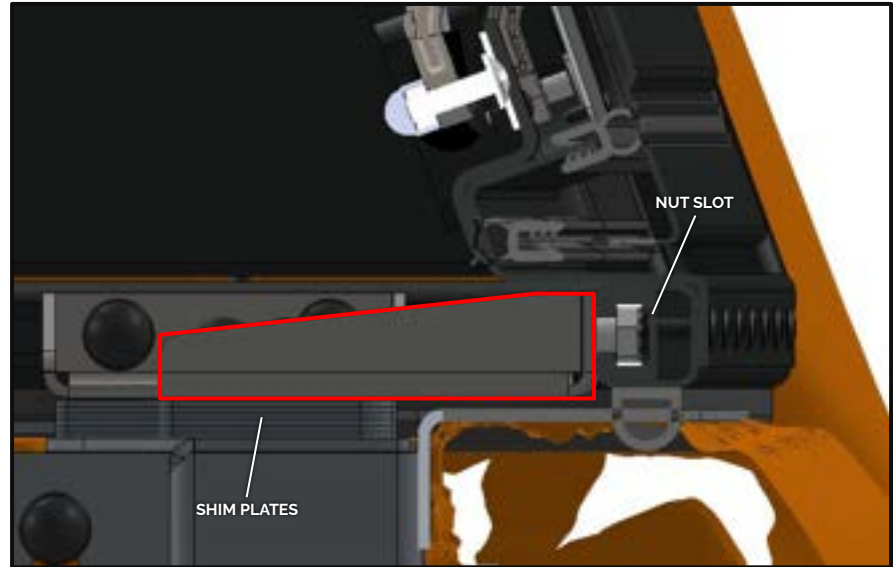
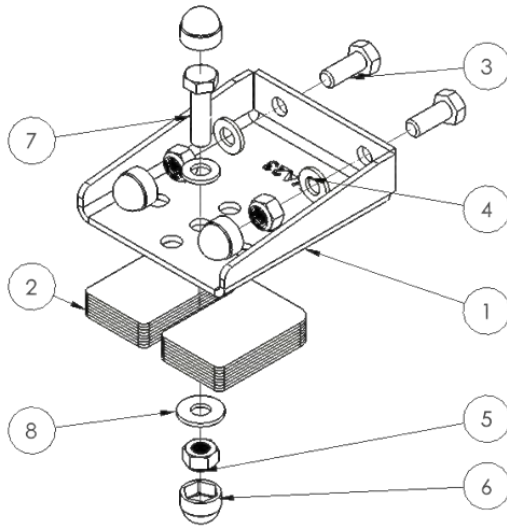

Fig 23. Ranger Canopy Mounting Bracket

Installation Instructions

4.3

Figure 24 below illustrates the Rear Canopy Mounting Bracket Sub-Assembly



ITEM NO.	PART NUMBER	DESCRIPTION	QTY
1	C2-VA23-M-BKT-P005	FORD RANGER CANOPY MOUNTING BRACKET	1
2	AC001-STD-SHIM-01	STANDARD SHIM 01	8
3	HEX-M8x20	M8x20 HEX BOLT S/S	2
4	FW-M8	M8x16mm FLAT WASHER S/S - DIN 125	3
5	NY-M8	M8 NYLOC NUT S/S	3
6	NCAP-M8	NUT CAP-08mm	4
7	HEX-M8x30	M8x30 HEX BOLT S/S	1
8	FFW-M8	M8x20mm OVERSIZED WASHER S/S - DIN 9021	1

Fig 24. Rear Canopy Mounting Bracket Assembly

Installation Instructions

4.4

Figure 25 below illustrates the Front Canopy Mounting Bracket Sub-Assembly

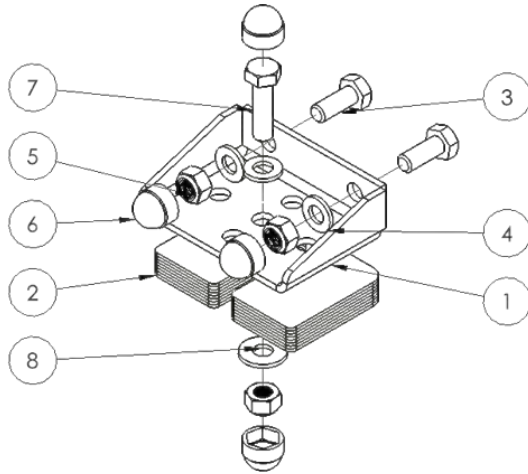

ITEM NO.	PART NUMBER	DESCRIPTION	QTY
1	AC001-CAN-MNT-BR KT-01	CANOPY MOUNTING BRACKET	1
2	AC001-STD-SHIM-01	STANDARD SHIM 01	8
3	HEX-M8x20	M8x20 HEX BOLT S/S	2
4	FW-M8	M8x16mm FLAT WASHER S/S - DIN 125	3
5	NY-M8	M8 NYLOC NUT S/S	3
6	NCAP-M8	NUT CAP-08mm	4
7	HEX-M8x30	M8x30 HEX BOLT S/S	1
8	FFW-M8	M8x20mm OVERSIZED WASHER S/S - DIN 9021	1

Fig 25. Front Canopy
 Mounting Bracket
 Assembly

Disclaimer

All rights reserved. No part of this website may be reproduced, translated, stored in a retrieval system, or transmitted, in any form or by any means, electronic, mechanical, photocopying, recording or otherwise, without prior written permission of the owner.

Review all instructions information carefully before installation.

Any damages, direct or incidental to the installer and/or property due to incorrect installation of any parts are the responsibility of the installer. Due to the various applications and fitment options available, the responsibility lies with the user to ensure all mounting points are secure and tight before every trip.

If unsure, consult with your Distributor regarding the operations of our products.

Users are advised to be mindful of the load they are carrying and drive in accordance with road conditions.

WARNING

Always wear appropriate PPE (Personal protection equipment) when fitting our products. Although the mounting kit is designed to be DIY, if you have any doubts or concerns, contact an accredited fitment centre to carry out the work. Alu-Cab will not be liable for any injury to persons, and/or damage to products and/or vehicles.

While Alu-Cab Holdings takes reasonable measures to ensure that the contents of this Website are accurate and complete, Alu-Cab Holdings makes no representations or warranties, whether express or implied, as to the quality, timeliness, operation, integrity, availability or functionality of this Website or as to the accuracy, completeness or reliability of any information on this Website. Alu-Cab Holdings reserves the right to make changes, corrections and/or improvements to the information and to the products and programs described in such information, at any time without notice.

Alu-Cab Holdings will use reasonable endeavours to maintain the availability of the Website, except during scheduled maintenance periods, and reserves the right to discontinue providing the Website or the service or any part thereof with or without notice to you. Any person who accesses this Website or relies on this Website or on the information contained in this Website does so at his or her own risk.

Occasionally, at our discretion, we may include or offer third-party products or services on our website. These third-party sites have separate and independent privacy policies. We therefore have no responsibility or liability for the content and activities of these linked sites. Nonetheless, we seek to protect the integrity of our site and welcome any feedback about these sites.